

MLS UNIVERSAL BUS TRANCEIVERS

UBT2000 & UBT2000DIN

The Universal Bus Transceiver expands the scope of The MLS Digital by enabling otherwise uncontrolled lighting and non-lighting loads to be brought into the system. UBTs also allow external devices to provide inputs into the system.

Universal Bus Transceivers are programmed to respond to signals from the MLS Digital Bus as part of a Group, Common and/or Building Zone and operate in the same way as all MLS Digital Detectors:

- Transmitting signals to the MLS Bus
 - following an external signal
- Receiving signals from the MLS Bus
 - to give an external output

A single UBT can perform both these functions at the same time.

UBT2000



UBT2000DIN



When commissioning, the following options are available (pre-sets shown in bold):

Function	Options	Description
Power-up	On/Off	Sets the Digital output and relay state at power-up irrespective of occupancy.
Response	Auto/Semi-auto	Auto: switches on and off automatically. Semi-auto: requires input commands on inputs 1-3 or the MLS Bus to switch on but switches off automatically.
Min on-time	No/Yes	If set to Yes, the luminaires stay on for at least 20 minutes regardless of the Off delay. Once the Minimum on-time has elapsed, the programmed Off delay is reinstated.
Off delay	5-60 min/ 20 min	Off delays are programmable in 5 minute steps with a 10 second walk-test option.
Bus connect	Yes/No	Selecting No electronically disconnects the unit from the bus.
Zones	1 to 50 -- (no zone)	Seven zones are listed which can be programmed at the time of commissioning. Detectors programmed to the same zone switch on or stay on when movement is detected anywhere in that zone. The 5th, 6th and 7th entries in the list may also be programmed as Common Zones or Global Zones (see Note 1 overleaf for a more detailed explanation of Global Zone operation).
Input 1-3	Various: Sustain	When the switch inputs go active, the programmed command is transmitted to the zones in the UBT's list.
Start lamps	Min/Max	Selects the digital dimming output at power-up which then adjusts to the required state.
Entry scene	1-6: Scene 1	Choose scene 1-6 which is selected when the area is first occupied.
Fade to off	No/Yes	After the Off delay, digital dimming output either switches off or fades to off gradually over a few minutes.
Vacant	Off Min Min 3hr Min bld Scn 6 Scn 6 3 hr Scn 6 bld	Switch off after off delay. Go to minimum until next occupancy. Go to minimum for 3 hours then switch off. Go to minimum until the building is vacated then switch off. Go to Exit Scene (Scene 6) until next occupancy. Go to Exit Scene (Scene 6) for 3 hours then switch off. Go to Exit Scene (Scene 6) until building is vacated then switch off.

USING THE UBT AS AN INTERFACE DEVICE (TRANSMITTER MODE)

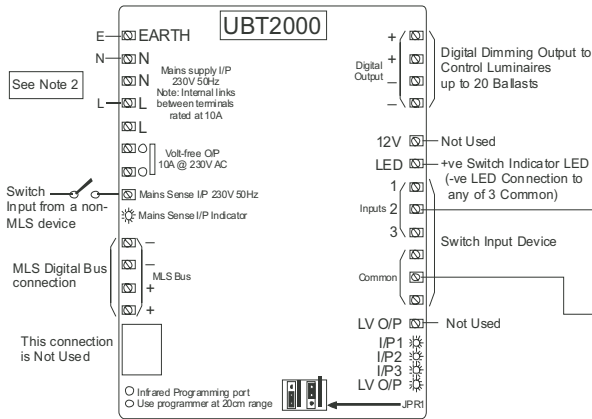

Input:

Signal on input 1, 2 or 3 from an external switch.

These inputs can be programmed to send Global Commands (which will be received by all devices programmed to accept Global Commands) as follows:

- SUSTAIN - Stay as you are
- OFF - Switch off
- SCENE 1-6 - Go to specified scene
- ON - Switch on to your entry scene.
- PARTITION - Causes any zone information programmed to the 3rd and 4th positions to be disregarded temporarily.

A momentary input will action the command and local presence will take over. A latched input will maintain the command regardless of presence until the input is opened.

Action:

The UBT's internal timer is started or refreshed.

Sends signal out on MLS Bus, communicating with similarly programmed devices on the same zones.

USING THE UBT TO RECEIVE SIGNALS FROM THE BUS TO SWITCH AN EXTERNAL NON-MLS DEVICE

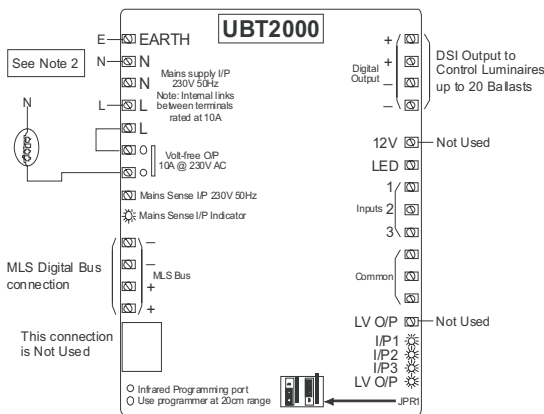

Input:

MLS Bus signal.

Action:

The UBT internal timer is started or refreshed.

Closes volt-free output - to operate external device/signal BMS etc.

TRANSCIEVER MODE

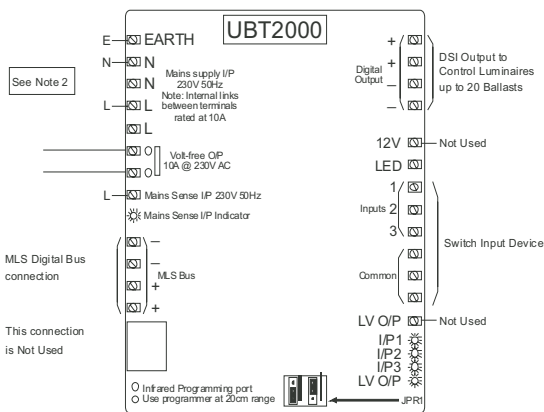

Input:

MLS Bus signal.

230V 50Hz signal on mains sense.

Signal on input 1, 2 or 3 from an external switch.

These inputs can be programmed to send Global Commands (which will be received by all devices programmed to accept Global Commands) as follows:

- SUSTAIN - Stay as you are
- OFF - Switch off
- SCENE 1-6 - Go to specified scene
- ON - Switch on to your entry scene.
- PARTITION - Causes any zone information programmed to the 3rd and 4th positions to be disregarded temporarily.

A momentary input will action the command and local presence will take over. A latched input will maintain the command regardless of presence until the input is opened.

Action:

The UBT's internal timer is started or refreshed.

Sends signal out on MLS Bus, communicating with similarly programmed devices on the same zones.

Note 1: The 5th, 6th and 7th Zones may be programmed as Global Zones.

A Global Zone may be used for load shedding or setting a scene for when the building is empty. There are two Global Zones that can either Transmit and Receive (G1 and G2 TxRx) or that can Receive only (G1 and G2 Rx). Global Zones are set by choosing Yes (they are pre-set to No) at the time of commissioning. In this way the UBT may broadcast information to other system devices (eg presence detectors) that are also programmed to be part of Global Zones.

Note 2: Please ensure that all mains-voltage connections are fed from the same phase as the UBT2000 power supply input.

Technical Data

RANGE TO HP2: 0.2m (8 inches)
 OPERATING VOLTAGE: 240V 50Hz
 PRODUCT RATING & RECOMMENDED CIRCUIT PROTECTION: 10 Amps

MAXIMUM RECOMMENDED LOAD: 10 Amps
 DIGITAL DIMMING OUTPUT LOAD: up to 20 BALLASTS
 WEIGHT: 112g SIZE: 175mm x 125mm x 75mm

Ordering Information

Part Number	Description	General Accessories
UBT2000	Universal Bus Transceiver (complete with enclosure)	HP2000 MLS Digital Programming Tool
UBT2000DIN	Universal Bus Transceiver for DIN Rail mounting	