

ecs EVOLUTION

POWER & PROCESSOR UNIT

36 CHANNELS

- THIRTY SIX CHANNELS of 3 amps resistive or 9 amps inductive loads, user selectable for dimming or switching.
- FULLY CONFIGURABLE control operation.
- MULTI-FUNCTION DSI, DMX, M-BUS, DALI,
- RS232, 0/1-10 Volt and contact operation.
- ASTRONOMICAL TIME CLOCK built in.
- INTELLIGENT SELF MONITORING power supply.
- SELF PROGRAM ON INSTALLATION facility for multi-unit applications.
- FACTORY SET DEFAULT operation for quick installation and testing.
- CIRCUIT PROTECTION individual 3 Amp Type C
- MCB for each channel.
- EMERGENCY OUTPUTS (2 per phase) fixed live
- MCB protected outputs for maintained emergency supplies.
- SUPPLY INPUT 200-250 Volt 50-60 Hz. Single or Three phase options.
- COMPLIES with EC EMC and Low Voltage Directives (CE).

Evolution is a versatile and highly configurable architectural control system designed for both lighting and peripheral management. Evolution is uniquely adaptable, making it an ideal choice for use in a vast number of applications including modern smart homes, shopping centres, restaurants, hotels, cruise ships, boardrooms, hospitality suites and offices.

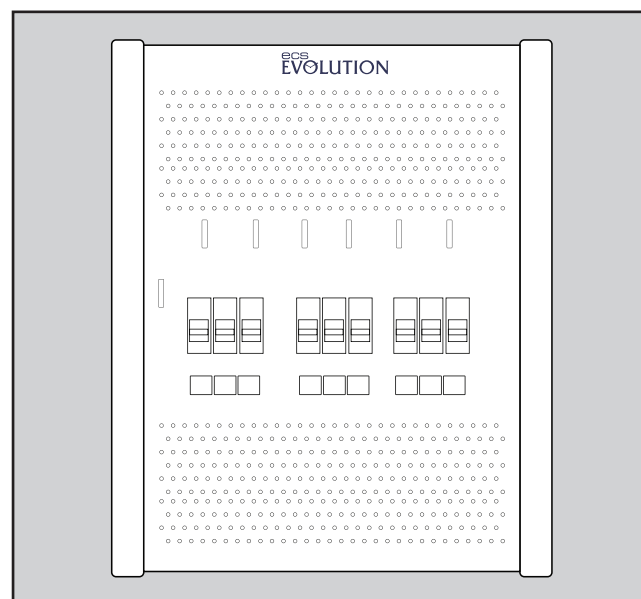

System features include RS232, DMX, DSI, DALI and 0/1-10v controls. A built-in astronomical clock facilitates events triggered at any time of day, linked with sunrise -sunset calculations or by user definable seasons.

Any input may control any output with the ability to provide operation of a sequence of events, for example, control of lighting, blind motors, commands to building management systems, colour changing etc. Unique features such as selfprogram-on-installation and distributed intelligence make the Evolution simple to install and maintain.

The Evolution power and processor unit builds on the quality and reliability of Mode product designs and offers high specification control and power management in a mechanically, electrically and thermo dynamically designed unit.

Technical Data

MAINS SUPPLY	230 Volt +/- 10% AC, 50-60Hz.	CONDUIT ENTRIES	Base entry. Five 32mm couplers or removable panel.
CONTROL FUSE	5mm x 20mm 2 amp HRC Ceramic. (3)	DIMENSIONS	534 mm x 482 mm x 160 mm.
EARTH	12 x 10 amp resistive (9 amp inductive).	FIXING CENTRES	452 mm x 464 mm.
CHANNEL OUTPUTS	Individual 6 amp Type C Miniature Circuit Breaker.	WEIGHT	17 kgs.
LOAD MCBS	M-BUS, RS232, DMX, DALI, 0/1-10V, DSI.	PACKED SIZE	600 mm x 550 mm x 250 mm.
CONTROL INPUTS	M-BUS, RS232, DMX, DALI, 0/1-10V, Contact Closure.	PACKED WEIGHT	18 kgs
RELAY OUTPUT	2 x SPCO (250VAC, 2A max) relay contacts.		
STANDARDS	EMC Emissions EN55015, EMC Immunity EN61547, Harmonics EN61000-3-2, Voltage fluctuation EN61000-3-3, Safety EN60439-1 and EN60950		

Internal Details

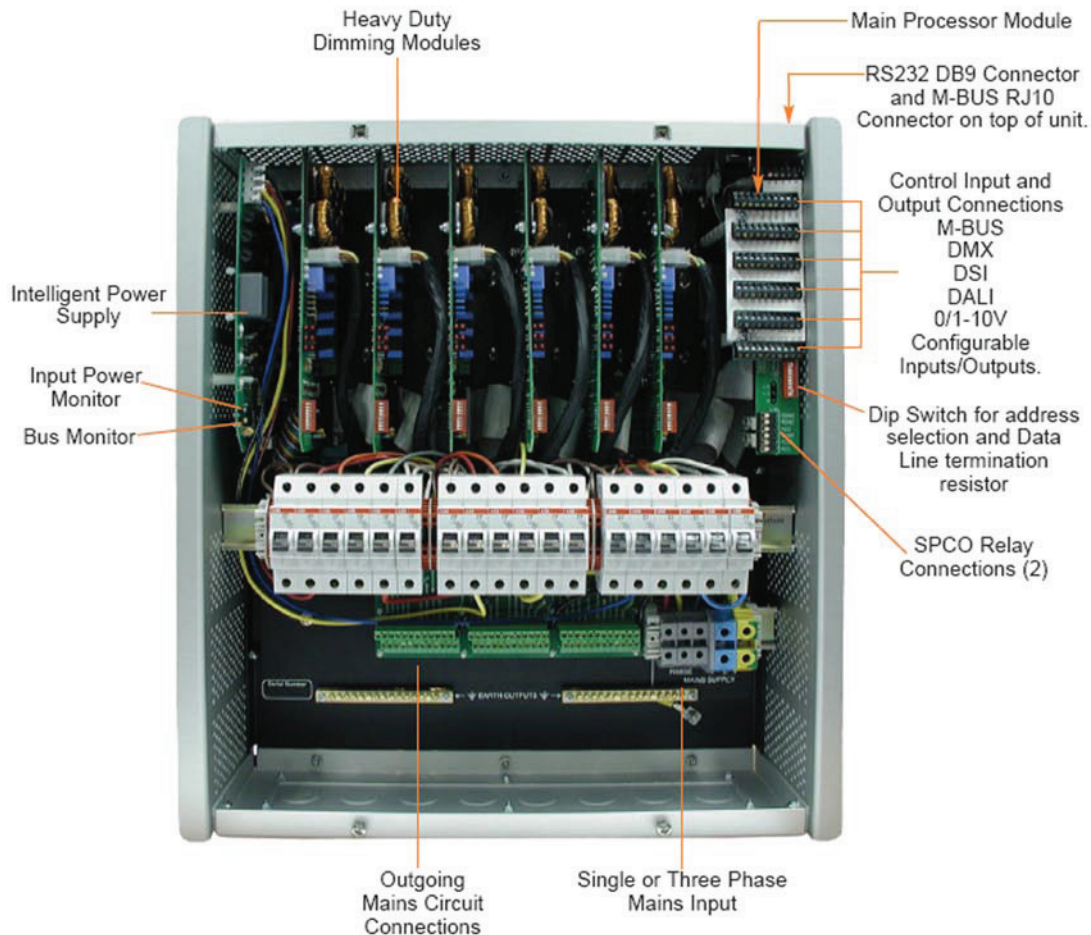

Ordering Information

Catalogue Number	Description
EVO-03-36	Power & Processor Unit