

MLS BUS POWER SUPPLY 'LITE'

RB2000LT

Overview

The RB2000LT is a low-cost Bus Power Supply for small buildings, or areas with fewer than 100 MLS devices (e.g. presence detectors).

In keeping with the low-cost theme, the RB2000LT can accept inputs from ordinary wall switches to manually override presence detectors (2000 series only, programmed to zones 1 and/or 2).

The RB2000LT is compatible with both 1200 and 2000 Series presence detectors and accessories, however only one series type can be supported at any one time.

Wiring the MLS Network

The MLS network consists of an unscreened twisted-pair which connects the bus power supply to every MLS device.

The MLS Bus may be wired in a free topology. Please refer to the wiring diagrams.

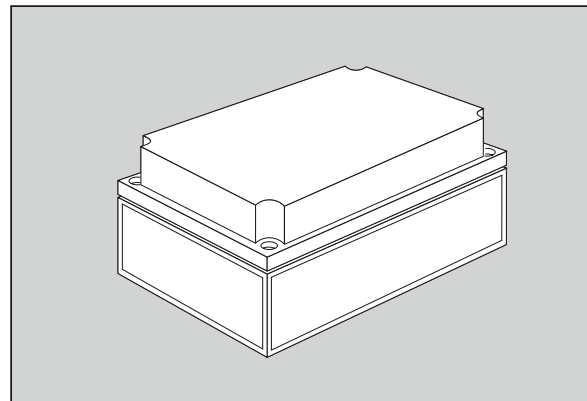

Features

Commissioning Mode - Enables easy testing of Bus functionality.

Switch Inputs - Appropriately programmed devices respond to switch inputs On, Off, Raise and Lower Light Level.

Up to 100 devices per RB2000LT system.

Please refer to MLS Wiring Diagrams for further detailed information regarding cable choice, wiring and system installation.

MLS bus cable:	Recommended - mains-rated unscreened twisted pair 1.5mm ²
Allowable bus length:	Not to exceed 1500m
Manual Wall Switching:	Any type of cable may be used, no practical limit to length
Connection:	Detectors may be connected in any order. Short spurs are permissible but are best avoided as they will not be checked during the integrity test.
Accurate as-fitted records will assist in fault finding.	
Mains wiring:	The bus may run with mains wiring provided unscreened twisted-pair is used.
Dimensions:	125 x 175 x 75mm
Weight:	112g